

# LENGTHEN command

2197 GstarCAD MY /KW April 14, 2022 [CAD Commands](#) 0 2288

The **LENGTHEN** command is used to change the length of objects and angles of arcs.

## Command Access:

**Ribbon** : Home > Modify > Lengthen

**Menu** : Modify > Lengthen

**Command** : LENGTHEN

## Command Prompts:

Select an object or [DElta/Percent/Total/DYnamic]:

## Function Description:

Users could change length or arc by specifying delta, percentage, total or dynamic. Using the LENGTHEN command is equivalent to TRIM or EXTEND command.

## Relative Glossary::

### Select an object:

Display the current length of selected line. The LENGTHEN command has no effect on closed objects. The direction of extrusion does not need to parallel to Z axis of current UCS.

### Delta:

Change the length of objects by specified delta, the value of delta is measured from the nearest end point of select objects. Users could also use this way to change angles of arcs. The value of delta is measured from the nearest end point of select arc. If the delta value is positive, the selected object will be extended, on the contrary if the delta value is negative, the selected object will be trimmed.

### Length:

change the length of object by a specified delta.

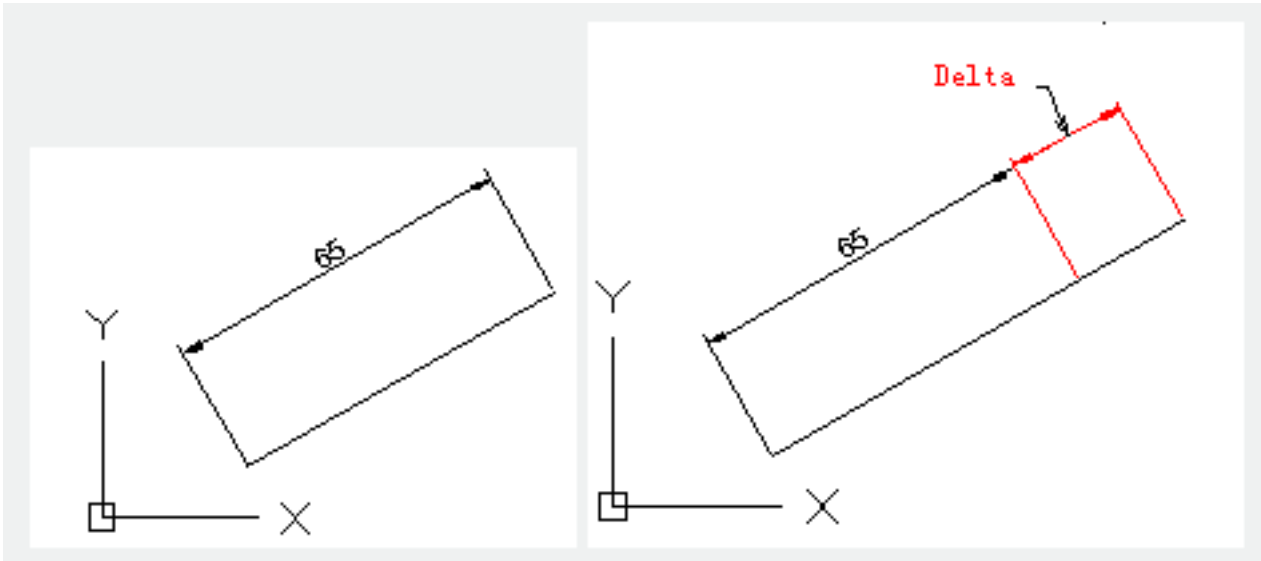

**Angle** :change the angle of object by specified delta.

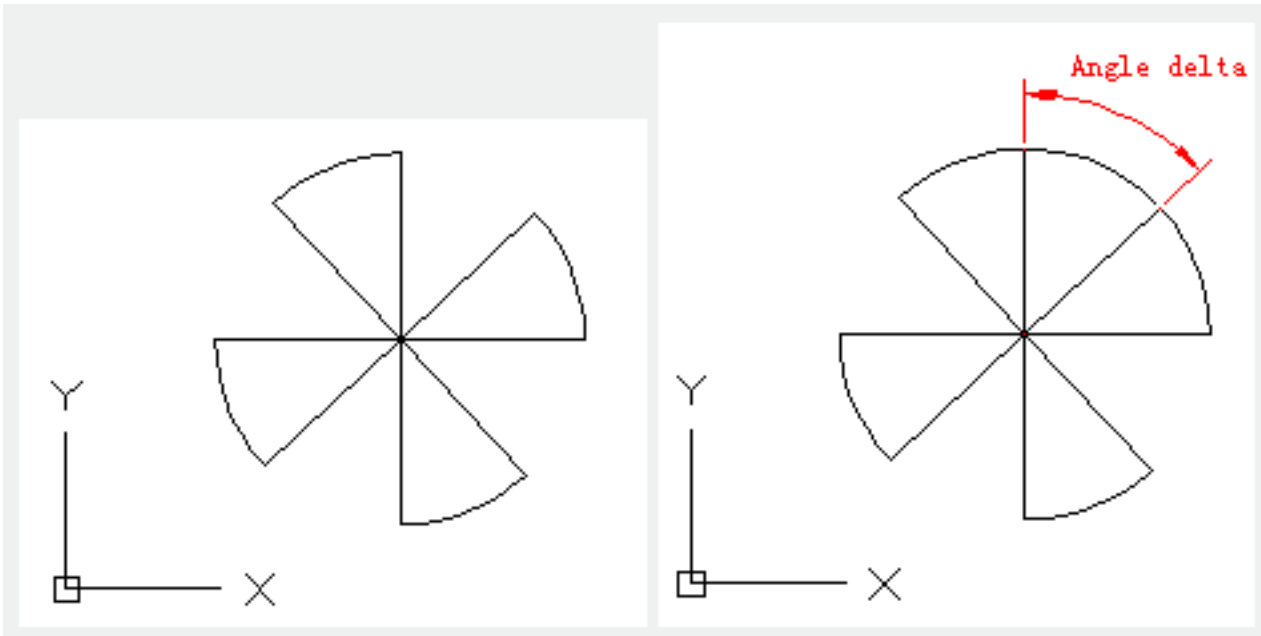

**Percent** : Specify the length of object by setting the percent of object total length.

**Length:**

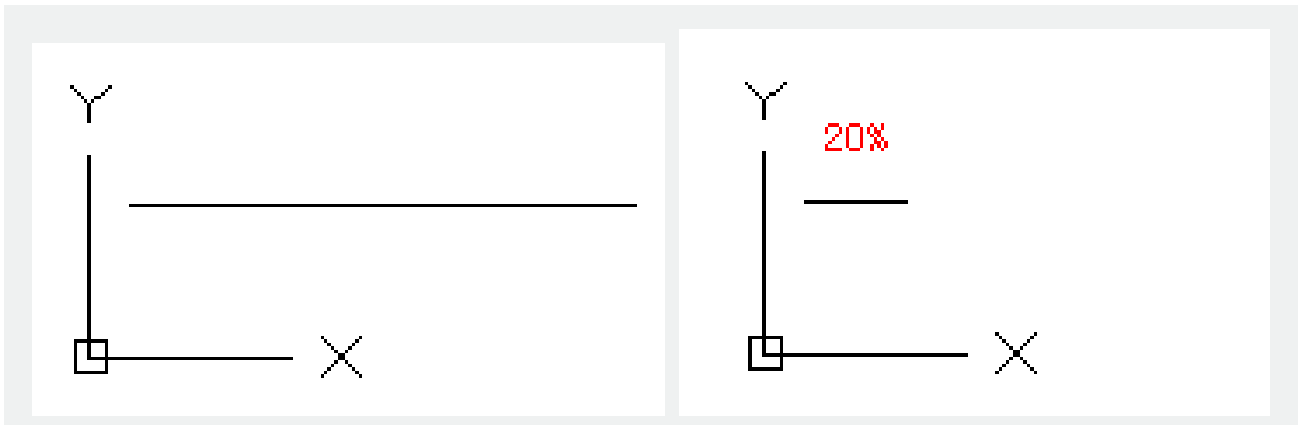

**Angle:**

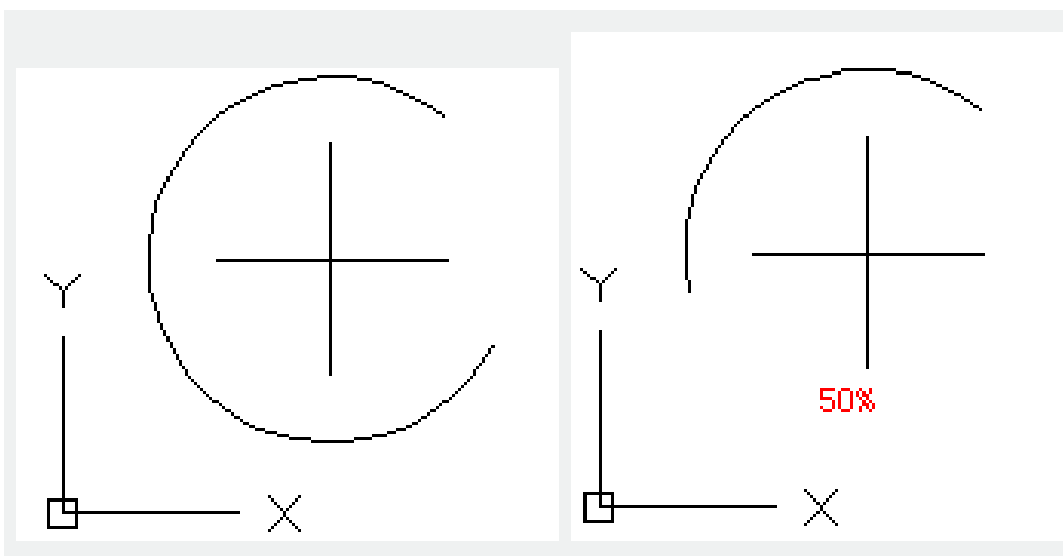

**Total:**

Specify the length of object by setting absolute value of the total length; the total length is measured from fixed end point. The "Total" option also specifies the angle of select arc by setting value of total angle.

**Total lengthen :** Stretch object from the endpoint that nearest from the selected point to specified total lengthen.

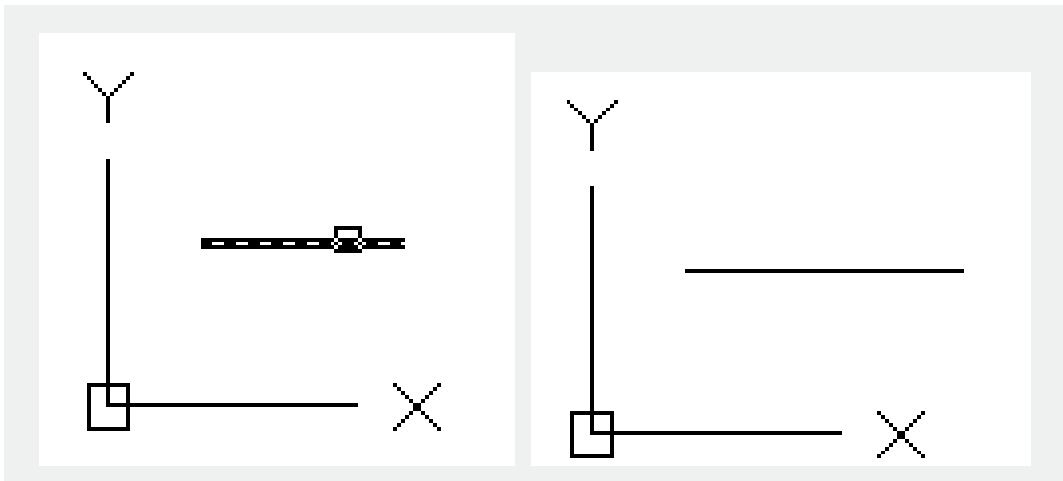

**Total angle** : Specify the total angle of selected angle.

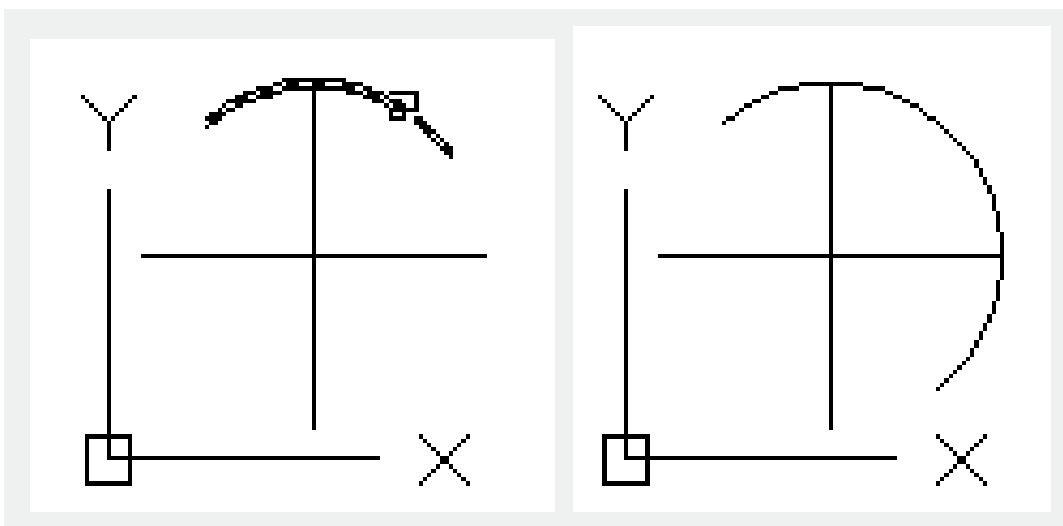

**Dynamic** : Turn on the dynamic drag mode, users could change lengthen of selected object by dragging one endpoint, and other endpoint remains unchanged

---

Related tutorial video:

- [Status bar related setting](#) 00:15
- [Draw Rectangles and Polygons](#) 00:26
- [Rectang command](#) 00:26
- [Polygon command](#) 00:26
- [Arc command](#) 00:30
- [Trim command](#) 00:40

- [Extend command](#) 01:51
- [Offset command](#) 02:23
- [Stretch command](#) 03:35
- [Edit objects + grips](#) 03:55
- [Break object](#) 04:13
- [Circle command](#) 05:51
- [Draw circles](#) 05:51
- [Break command](#) 05:56
- [Join command](#) 06:32
- [Scale command](#) 06:53
- [Lengthen command](#) 07:29
- [Copy command](#) 08:20
- [Rotate command](#) 08:47
- [Move command](#) 09:07

Above video sources from [TUTORIAL - GETTING STARTED WITH GSTARCAD](#), enrol now for free.

Online URL: <https://www.kb2.gstarcad.com.my/article.php?id=2197>